

REL – 0.3 Te WLL - 200m - Electric Winch



TECHNICAL SPECIFICATION

Weight without cable (Kg)	Cable diameter (mm)	Capacity (m)	Line speed (m/min)		WLL (Kg)		Brake (Kg) Minimum 1.5 WLL	
			First Layer	Top Layer	First Layer	Top Layer	First Layer	Top Layer
1620	48	200	32	42	300	229	450	344
Supply Required		380-440V-3 Ph- 50/60 Hz			Frame details		Crash frame with guards, fork lifting pockets and certified lifting lugs	
Winch Electrical Motor		2.2 Kw IP56 IE3			Winch drum dimensions		Drum core \varnothing 1200 mm, Drum Length 480 mm, Flange \varnothing 1980 mm	
Local Proportional Control		Bi-directionally proportional joystick and speed control potentiometer			Drum details		Plain drum; the umbilical is stored in 5 lays with 10 turns per lay	
Level wind		N/A			Drum flanges 4 off - \varnothing 20 mm holes		To enable the winch drum to be "stoppered" off to a lug on the frame during long tow	
Dimensions (LxWxH) Footprint		2165 x 1258 x 2080 mm 2120 x 1170 mm			Cable		Mini-Streamer \varnothing 48 mm	
Slip ring		Designed to accept Focal 180 or similar not within scope of supply			Forward support cross bar		Easily removable, via bolts, to allow equipment to pass	

Principle of Operation:

The winch barrel is mounted directly onto the outer face of a vertically mounted slew-ring bearing. The inner ring of the bearing has been mounted onto the frame support.

The winch barrel is driven directly from a Brevini gearbox and a 2.2 kW SEW Electric Motor combination fitted with a failsafe brake unit. The brake, being failsafe, always defaults to on should, for any reason, the electrical supply is lost or the joystick is in its centre (neutral) position.

The Electric Survey Winch can be driven bi-directionally using a proportional joystick, which is mounted locally on the side of the electrical enclosure, the proportional joystick controls both the direction and the speed of the winch in heave and pay out.

The winch is supplied with the following:

- 1 Set - sacrificial steel feet/mounting plates for mounting at ship
- Marine grade paint system (Details can be supplied on application)
- 1 Set - Master Links and Shackles or a 4 leg lifting sling and shackles
- 12 Month Warranty
- Canvas Cover for transport and storage
- Operation and Maintenance Manual in Electronic Format

Optional extras: - please note these are not in the scope of supply but can be offered at extra cost.

- 1 Off – Slip Ring details to be supplied with order
- 1 Off – Extended Warranty
- 1 Off – Full Spares Kit
- 1 Off – Winch running flashing lights and/or Klaxon
- 1 Set – Spare sacrificial feet/mounting plates
- Remote Control wired or wireless



Romica Engineering Ltd (UK)

Romica Business Centre,
Beck View Road, Grovehill Road
Beverley, HU17 0JT, United Kingdom
P: (+44) 148 285 3884
F: (+44) 148 285 3884
www: <http://romica.co.uk/>



REV	DESCRIPTION
1	

THIRD ANGLE PROJECTION

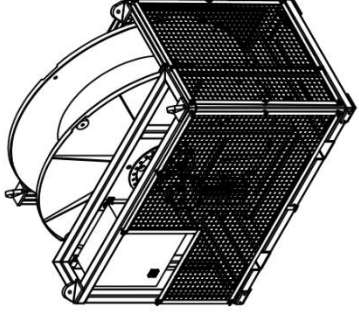
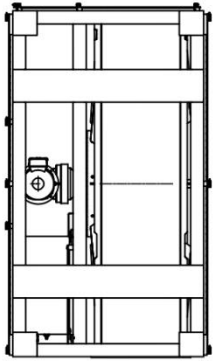
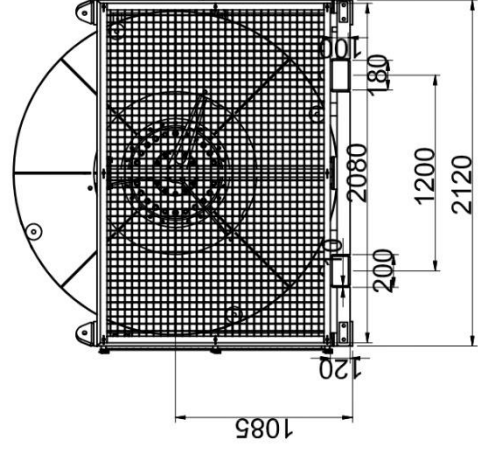
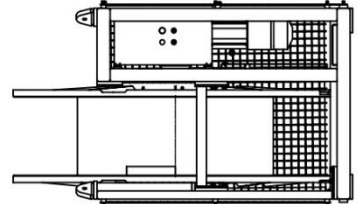
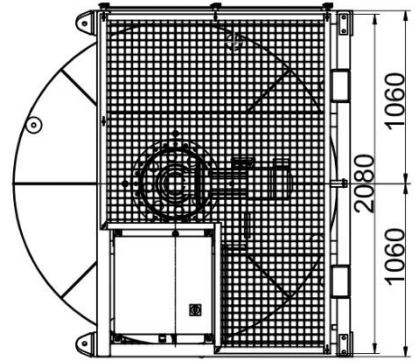
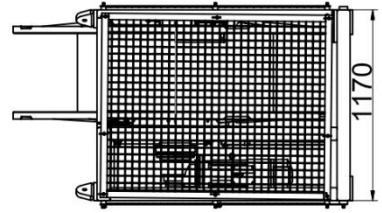
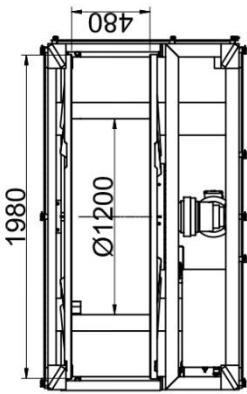

WEIGHT		CABLE		CAPACITY		LINE SPEED		SWL		BRAKE	
DRUM CORE DIAMETER	CABLE DIAMETER	DRUM LAYER	TOP LAYER	DRUM LAYER	TOP LAYER	DRUM LAYER	TOP LAYER	DRUM LAYER	TOP LAYER	DRUM LAYER	TOP LAYER
1,020 kg	48 mm	2,000 kg	2,200 kg	2,000 kg	2,200 kg	2,000 kg	2,200 kg	2,000 kg	2,200 kg	2,000 kg	2,200 kg

ITEM	PART No.	DESCRIPTION	No OFF	MATL	WEIGHT

romicaengineering
 Romica Engineering Limited, Romica Business Centre, Beck View Road,
 Romica, Romica, Romica
 Tel: +44 (0)1452 823844 | Email: sales@romica.co.uk
 www.romica.co.uk

TECHNICAL SPECIFICATION	
DRUM CORE DIAMETER	1,020 mm
CABLE DIAMETER	48 mm
CAPACITY	2,000 kg
LINE SPEED	30 m/min
SWL	2,000 kg
DRUM LAYER	2,000 kg
TOP LAYER	2,200 kg
DRUM LAYER	2,000 kg
TOP LAYER	2,200 kg
BRAKE	2,000 kg
DRUM LAYER	2,000 kg
TOP LAYER	2,200 kg

CONFIDENTIAL INFORMATION	
ISSUE	1.
DESIGNED	MB
CHECKED	SH
APPROVED	SH
DATE	15.06.2018

TITLE	
REL 0.3Te WLL Electric Winch	DS03
DRG. No.	A2
	SHIT 1
	OF 1